



LS-5 Series

LS-511/521

Circuit Breaker Control & Protection

DESCRIPTION

The LS-5 Series are synchronizer controllers with integrated protective functions. They are designed to enable complex power management applications with multiple incoming mains and bus breakers in combination with easYgen-3400/3500 equipped genset controllers.

The LS-5 devices will manage synchronization, loading and un-loading on each bus segment and send the required voltage and frequency references via CAN bus to the easYgen-3400/3500 genset controllers. LS-5 devices which are located on the incoming mains breakers will automatically detect mains failures and start the corresponding gensets accordingly. Wiring efforts are reduced to a minimum, since only one CAN bus connection is required between all LS-5 and easYgen-3400/3500 controllers. It is not required to wire any AC measurement signals or discrete inputs/outputs between the LS-5 and easYgen-3400/3500 controllers.

Extensive remote control capabilities via discrete inputs or interfaces are provided to easily integrate the LS-5 into each application environment.

The LS-5 Series is available in two different housing versions. The LS-521 with a plastic housing and graphic LCD display is designed to be mounted on the cabinet's front door. The LS-511 with an aluminum powder coated housing without display is designed to be back panel DIN Rail mounted.

FEATURES

- Up to 16 LS-5 units can be operated in one network with up to 32 easYgen-3400/3500
 - Phase match or slip frequency synchronization with voltage matching
 - Full protection package (including df/dt (ROCOF), phase shift and mains voltage increasing protection according to new German grid code requirements in VDE-0126-1-1)
 - Segment control for the load sharing
 - Event Log with up to 300 entries
 - Automatic date and time synchronization between the LS-5 units and the connected easYgen-3400/3500 controls
 - LS-5 "Stand alone" mode without the easYgen-3400/3500 is possible
 - Preconfigured application modes for the most common applications in the field (MCB or MCB/GGB application)
 - Automatic and Manual mode
 - Full remote control via CAN or RS-485 interface
 - In case transformers are used in the application, vector group adjustment is available
 - Breaker open/close failure detection
 - Mains decoupling "Test" mode
 - Multilingual capability
 - Lock Keypad feature
 - 8 Freely configurable LED's are available on the LS-511 back panel mountable device
- Designed as solution for complex power management applications
 - Up to 16 LS-5 units can be utilized in one application
 - Up to 32 bus segments are possible
 - Synchronization and protection in one compact controller
 - Adjustable vector groups for Synchronization
 - Automatic mains failure detection
 - Automatic and Manual mode
 - LS-5 "Stand alone" mode for use without easYgen-3400/3500 System
 - LogicsManager functionality
 - CAN and RS-485 interfaces for remote control and visualization purposes
 - True RMS sensing
 - Available as cabinet front door mounted device or DIN-Rail back panel mounted metal housing
 - Freely configurable relay outputs
 - Freely configurable discrete inputs
 - QV monitoring
 - Time-dependent voltage monitoring

SPECIFICATIONS

Power supply..... 12/24 Vdc (8 to 40 Vdc)
 Intrinsic consumption max.~ 5 W (LS-511)
 max.~ 6 W (LS-521)
 Ambient temperature (operation).....-20 to 70 °C / -4 to 158 °F
 Ambient temperature (storage).....-30 to 85 °C / -22 to 185 °F
 Ambient humidity.....95 %, non-condensing
Voltage ($\sqrt{\Delta}$)
 120 Vac [1] Rated (V_{rated}).....69/120 Vac
 Max. value (V_{max}).....86/150 Vac
 Rated voltage phase – ground150 Vac
 Surge volt. (V_{surge}).....2.5 kV
and 480 Vac [4] Rated (V_{rated}).....277/480 Vac
 Max. value (V_{max}).....346/600 Vac
 Rated voltage phase – ground300 Vac
 Surge volt. (V_{surge}).....4.0 kV
 AccuracyClass 1
 Linear measuring range1.25× V_{rated}
 Measuring frequency.....50/60 Hz (40 to 85 Hz)
 High Impedance Input; Resistance per path.....[1] 0.498 M Ω , [4] 2.0 M Ω
 Max. power consumption per path.....< 0.15 W
Current (Isolated) Rated (I_{rated}).....[1] ..1 A or [5] ..1/5 A
 Linear measuring range $I_{gen} = 1.5 \times I_{rated}$
 Burden.....< 0.15 VA
 Rated short-time current (1 s).....[1] 50× I_{rated} , [5] 10× I_{rated}
Discrete inputsisolated
 Input range12/24 Vdc (8 to 40 Vdc)
 Input resistance..... approx. 20 kOhms

Relay outputspotential free
 Contact material.....AgCdO
 Load (GP)2.00 Aac@250 Vac
 2.00 Adc@24 Vdc / 0.36 Adc@125 Vdc / 0.18 Adc@250 Vdc
 Pilot duty (PD).....
 1.00 Adc@24 Vdc / 0.22 Adc@125 Vdc / 0.10 Adc@250 Vdc
Housing (LS-521) Front door mounting..... Plastic housing
 Dimensions WxHxD219 × 171 × 61 mm
 Front cutout WxH186 [+1.1] × 138 [+1.0] mm
 Connection.....screw/plug terminals 2.5 mm²
 Front.....insulating surface
 Sealing Front.....IP65 (with screw fastening)
 Front.....IP54 (with clamp fastening)
 BackIP20
 Weight.....approx. 850 g
Housing (LS-511) Back panel mounting.....Sheet metal housing
 Dimensions WxHxD190 × 167 × 47 mm
 Connection.....screw/plug terminals 2.5 mm²
 Protection systemIP 20
 Weight.....approx. 840 g
Disturbance test (CE)tested according to applicable EN guidelines
ListingsUL/cUL, GOST-R
MarineLR (Type Approval), ABS (Design Assessment)

DIMENSIONS

Plastic housing for front panel mounting

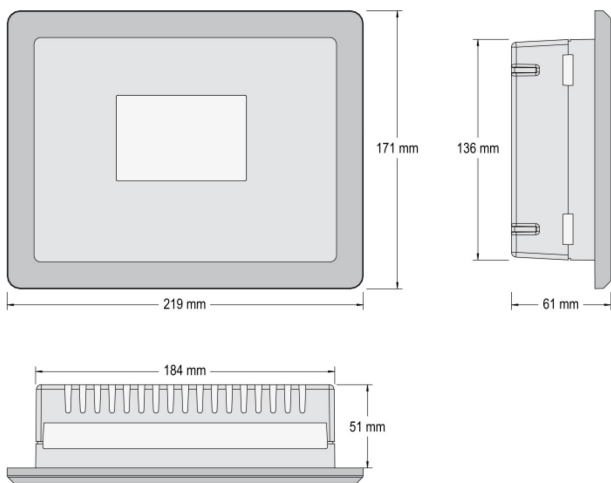

Metal housing for cabinet mounting

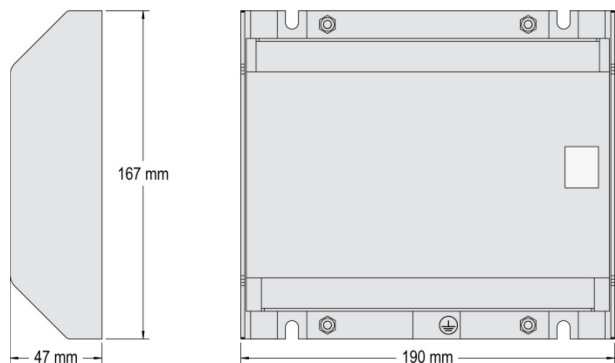

TERMINAL DIAGRAM

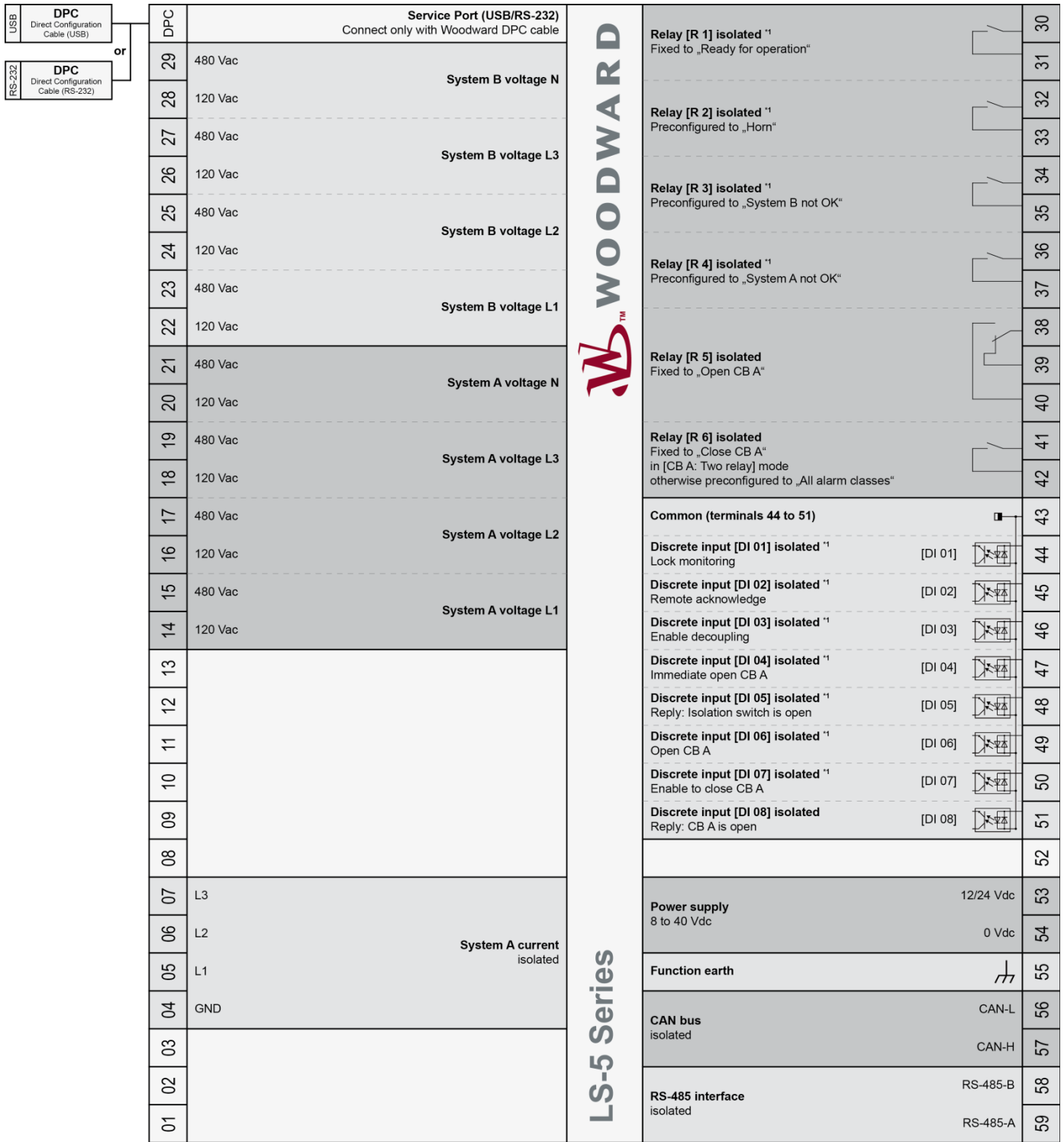

Subject to technical modifications.

^{*1} = configurable via LogicsManager

LS-5 Series Wiring Diagram | Rev. A

CONTACT

North & Central America

Tel.: +1 970 962 7331
 ✉ SalesPGD_NAandCA@woodward.com

South America

Tel.: +55 19 3708 4800
 ✉ SalesPGD_SA@woodward.com

Europe

Tel. Stuttgart: +49 711 78954 510
 Tel. Kempen: +49 2152 145 331
 ✉ SalesPGD_EUROPE@woodward.com

Middle East & Africa

Tel.: +971 2 6275185
 ✉ SalesPGD_MEA@woodward.com

Russia

Tel.: +7 812 319 3007
 ✉ SalesPGD_RUSSIA@woodward.com

China

Tel.: +86 512 8818 5515
 ✉ SalesPGD_CHINA@woodward.com

India

Tel.: +91 124 4399 500
 ✉ SalesPGD_INDIA@woodward.com

ASEAN & Oceania

Tel.: +49 711 78954 510
 ✉ SalesPGD_ASEAN@woodward.com

www.woodward.com

Subject to alterations, errors excepted.

Subject to technical modifications.

This document is distributed for informational purposes only. It is not to be construed as creating or becoming part of any Woodward Company contractual or warranty obligation unless expressly stated in a written sales contract.

We appreciate your comments about the content of our publications. Please send comments including the document number below to stqt-doc@woodward.com

© **Woodward**
All Rights Reserved

For more information contact:



U.S. Toll Free 877-544-5201
 Lada S/C Mexico 888-418-DRAK (3725)
www.drakecontrols.com

EXAMPLE APPLICATION

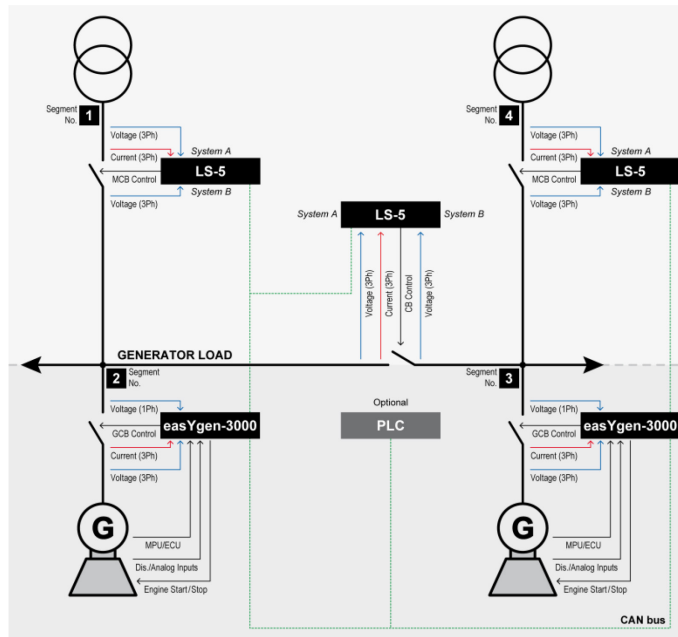

FEATURES OVERVIEW

	LS-511	LS-521
I/Os		
Display	No	Yes
Configurable LEDs on Faceplate	Yes	No
System A/B voltage measurement	3-Phases + Neutral	3-Phases + Neutral
System A current measurement	3-Phase	3-Phase
Discrete inputs	8	8
Relay outputs	6	6
CAN Interface	1	1
RS-485 Interface	1	1
Control		
Automatic and Manual operating modes	✓	✓
Breaker synchronization (slip synchronization /phase matching)	✓	✓
Vector group adjustment for synchronization	✓	✓
Configurable dead bus closure direction	✓	✓
HMI		
Configuration via HMI and PC	✓	✓
Event recorder with real time clock (battery backup)	✓	✓
Date and Time Synchronization between LS-5 units and easYgen-3400/3500-P1	✓	✓
Protection		
Over-/undervoltage (59/27)	✓	✓
Over-/underfrequency (81O/U)	✓	✓
Voltage asymmetry (47)	✓	✓
Phase shift (78)	✓	✓
df/dt (ROCOF) (81)	✓	✓
QV monitoring	✓	✓
Time-dependent voltage	✓	✓
Mains voltage increase (accord. to VDE-AR-N-4105)	✓	✓
Monitoring		
Breaker open/close monitoring	✓	✓
Synchronization time out monitoring	✓	✓
Counter		
Circuit breaker closure counter	✓	✓
Listings/Approvals		
UL / cUL / GOST-R / LR & ABS Marine	✓	✓
CE Marked	✓	✓
Part Numbers		
LS-511 (1A / 5A)	8440-1951 / 8440-1946	---
LS-521 (1A / 5A)	---	8440-1952 / 8440-1947
DIN-Rail mounting Kit for LS-511	8923-1746	---
DPC-RS-232 direct configuration cable		5417-557
DPC-USB direct configuration cable		5417-1251